

# TRAGUS

466-14-VB

Taking cues from the faceted shapes found in Noz Nozawa's jewelry design sketches, Tragus resembles a gem suspended on a necklace. The design features a faceted inner clear glass shade and a curved outer glass in light bronze, striking a balance between intrigue and approachability. The inclusion of decorative metal detailing and a mariner chain, developed specifically for Noz, enhances the illusion. Tragus is available in two sizes in a Vintage Brass finish. Part of our Noz Nozawa collection.

## FINISHES

### VINTAGE BRASS

Coastal Suitable Finish (EPM): No

## DIMENSIONS

Height: 19.25"

Width/Diameter: 14"

Minimum Height: 32.25"

Maximum Height: 93.75"

Canopy/Backplate: 9.5"

Hanging Type: 72" Chain

Product Weight: 19.54lb

Canopy/Backplate Shape: Round

Sloped Ceiling Compatible: No

Living Finish: Yes

Uplight Only: No

## Shade

Shade 1: Glass

Shade 1 Finish: Light Bronze

Shade 1 Top Width: 6"

Shade 1 Bottom L/W: 0" / 14"

Shade 1 Height: 17.75"

Shade 2: Glass

Shade 2 Finish: Clear

Shade 2 Top Width: 3.25"

Shade 2 Bottom L/W: 0" / 7.5"

Shade 2 Height: 15.25"

## ELECTRICAL



### Bulb 1

Bulb Included: No

Socket: E26 Medium Base

Bulb Type: A19

Max Wattage: 15

Bulb Quantity: 1

Bulb Included: No

Wire Length: 120"

Cord Type: SPT-1 SILVER W/ TINNED GROUND WIRE

Gem Box Required (2"x3"): No

Dark Sky: No

## SHIPPING

Carton 1: 27" x 22" x 21"

Carton 1 Weight: 25lb

Shipping Method: Ground

Country of Origin: VN

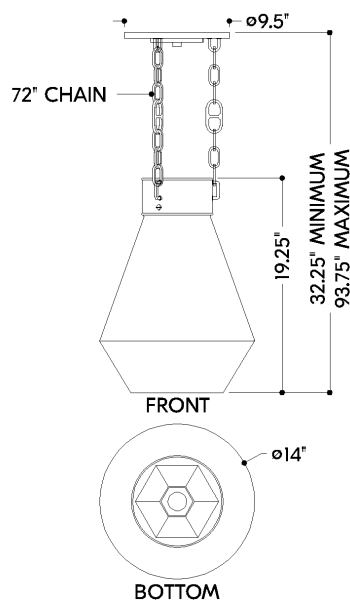

HUDSON VALLEY  
LIGHTING GROUP

| hvlgroup.com | 1.800.814.3993

REVISED 3.11.2022